



HONORABLE MENTION

Project Title

A Study of Brick Walls

Student Name

Ching-Hang Lee

Level

Graduate

Course

Thesis

Advisor/Instructor

Chen-Cheng Chen

Principal Investigator

Chen-Cheng Chen

Department/School

**Department of Architecture,
Tamkang University, Tanshui, Taiwan**

Summary description of project:

This student studies different possibilities for laying brick walls, which use methods other than plain texture mapping. The actual methods explored and discussed are based on the geometry or physical shape of bricks and the different ways in which they can be laid out and picked. These explorations produced some very interesting results. At the end of the project, these brick pavilions are designed near the ocean. They function as places from where one can observe the rain, the ocean, and the sky.

Reasons for the nomination:

Instead of apply texture mapping to describe brick walls, this project inserts the brick element one by one in the **form•Z** environment. Through simple manipulations on geometries and transformations, this project produces interesting patterns for brick walls.

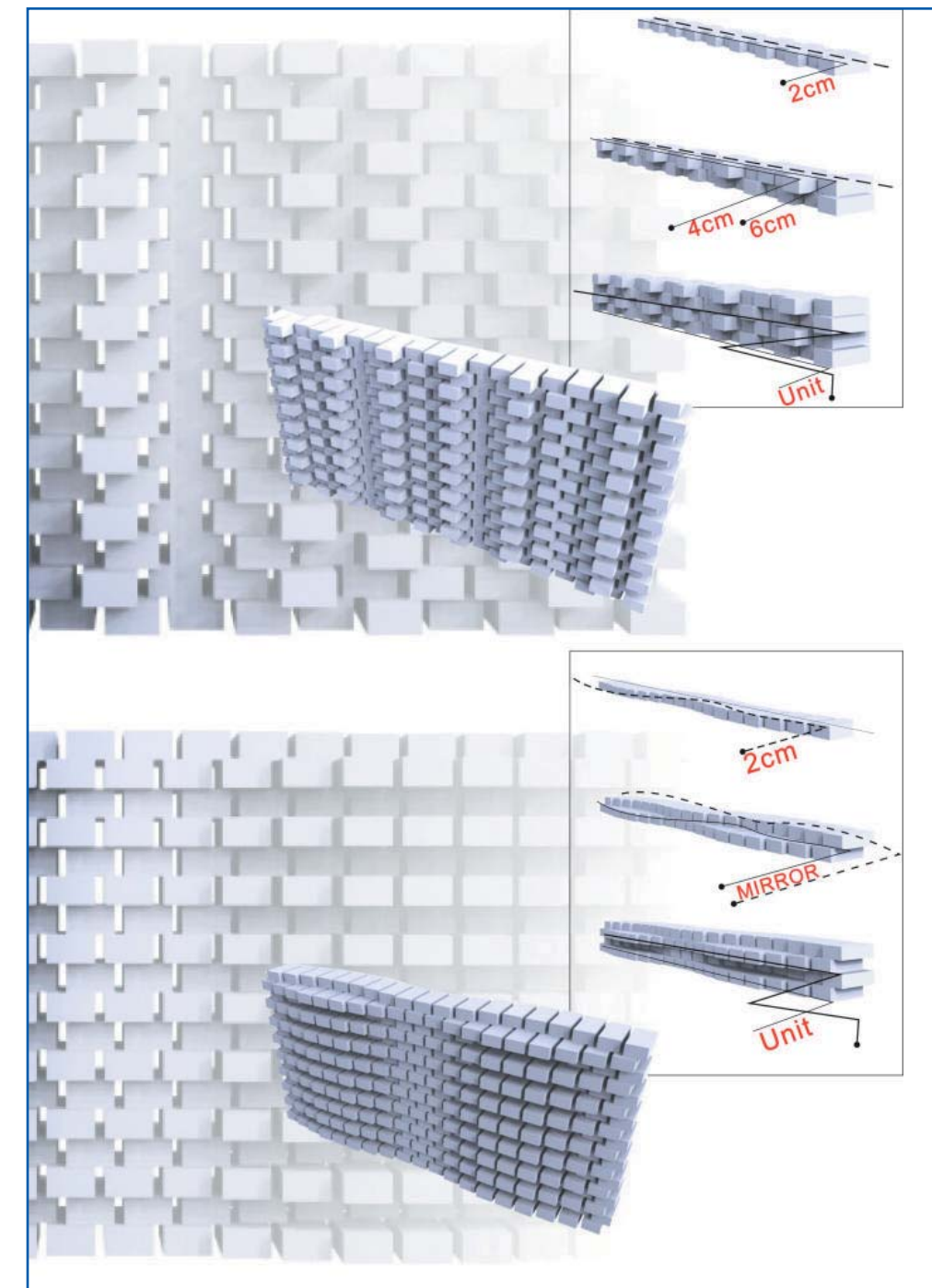
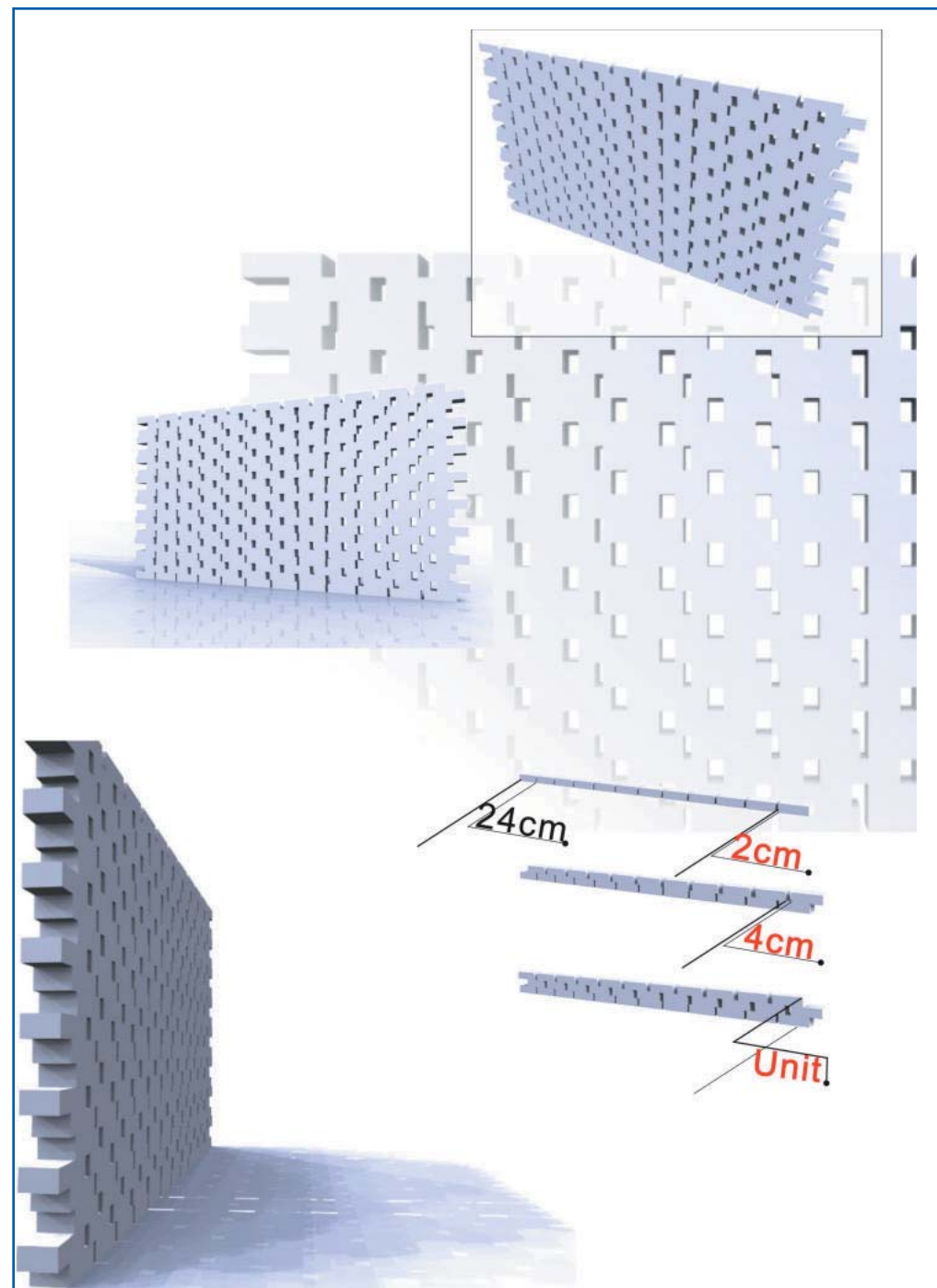

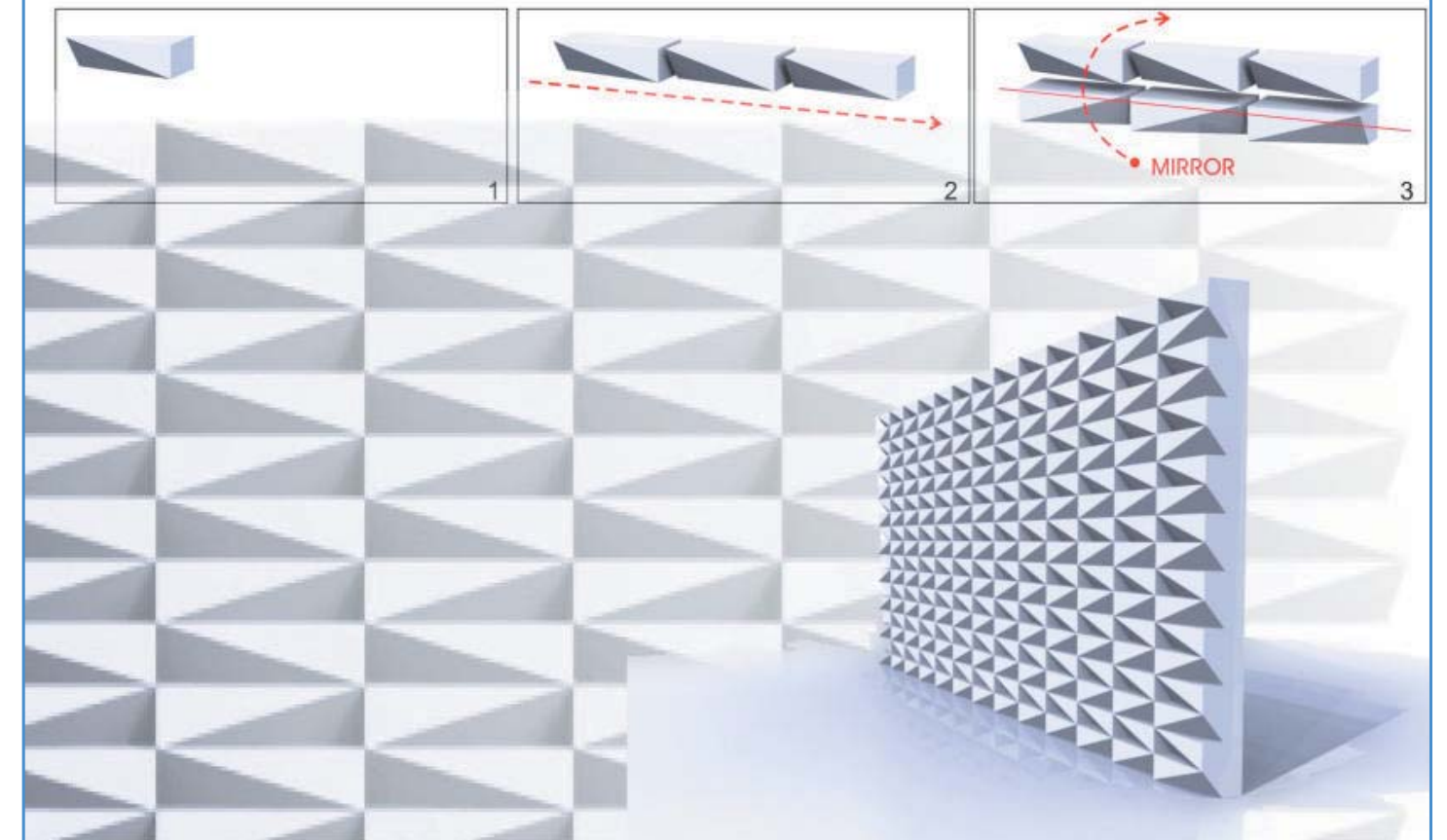
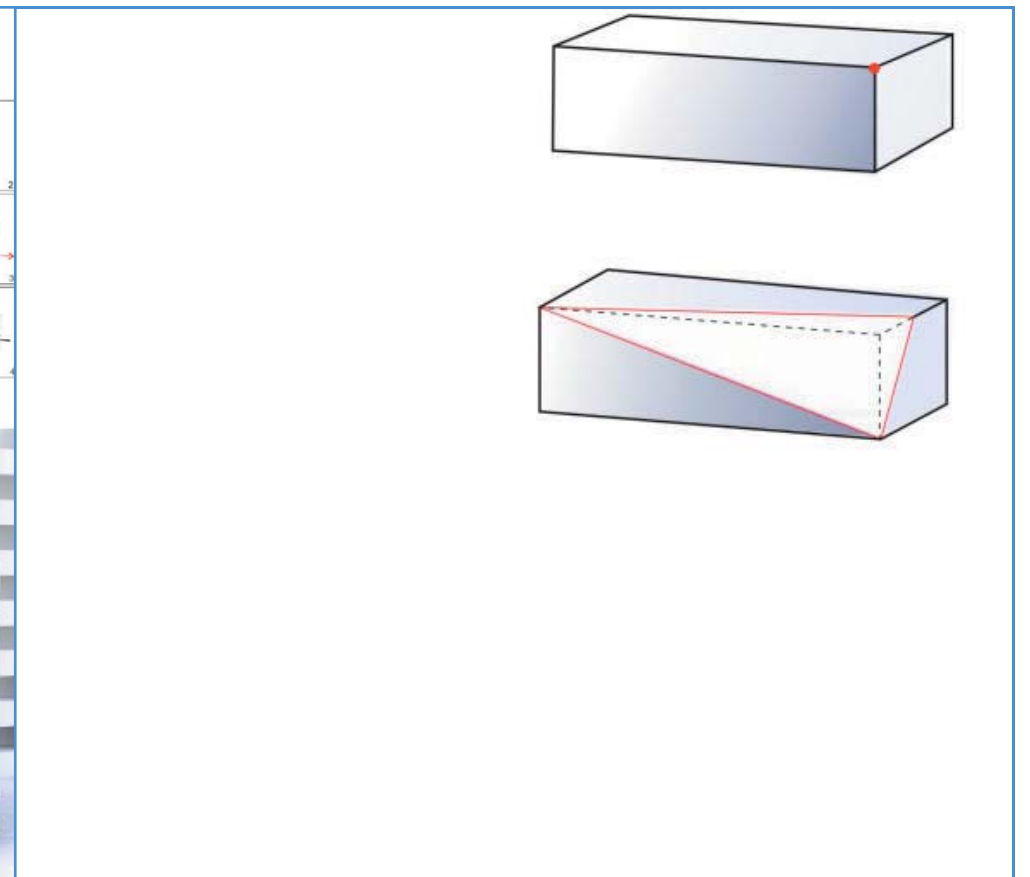
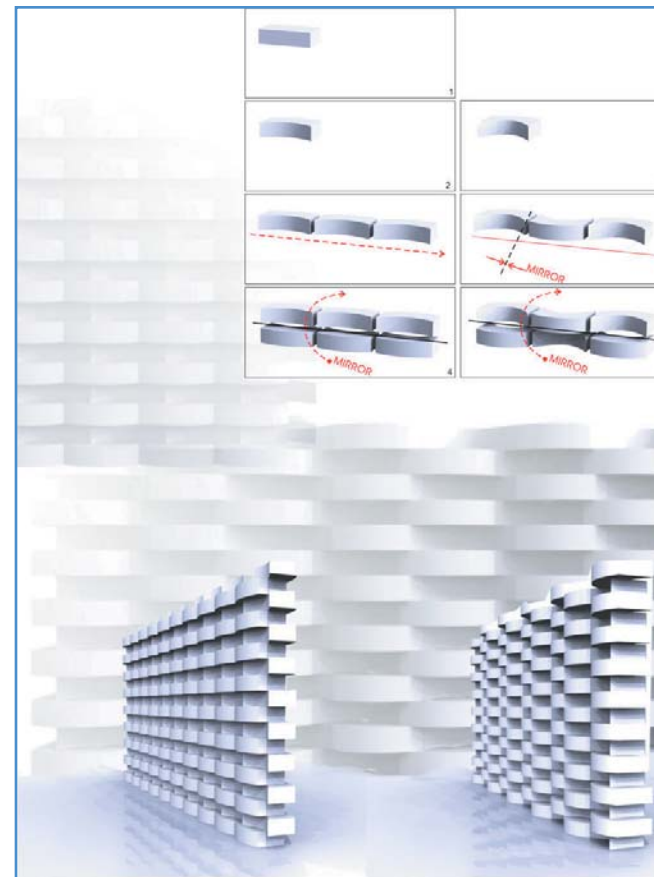
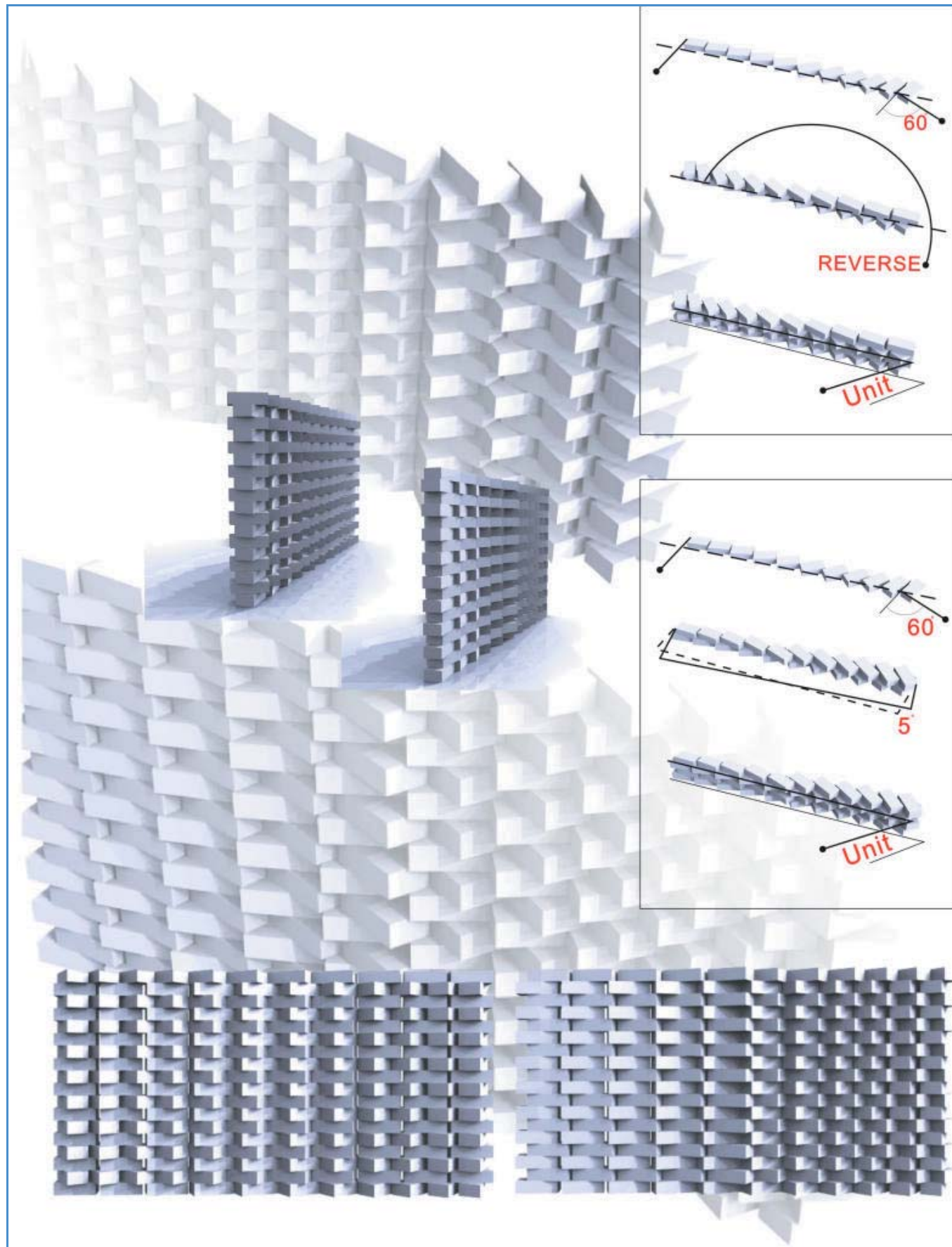

Jury comments:

Here we see the intrinsic role of digital media in exploring what is essentially a shape grammar approach. Clearly, the explorations would have been onerous or downright dangerous if done with the actual bricks. Thus, the use of digital medium to conceptualize, develop, and concretize a material-based exploration is indispensable. The project pitches a plausible design proposition if we set aside the questions of structural stability, robustness of the system and the system of actual construction with or without mortar joints.

I would have liked to see the project actually built either in a model form or as a proof-of-concept construction. It appears that the designer onerously built the digital models literally brick-by-brick, row-by-row, and operation-by-operation, which is ironic! A truly computational and algorithmic approach would have allowed the designer to generate and test far more number and types of possibilities.
—Mahesh Senagala

